



Kong Lighting Technology Ltd

HK Office: Flat 24, 8/F, Block A, Hoi Luen Industry Centre, 55 Hoi Yuen Rd, Kwun Tong, Kowloon, Hong Kong
Tel: (852) 2185 7600, Fax: (852) 2185 7608
WWW.Konglighting.com

China Factory: Lijiafang Industry Zone, Shipai, Zhen, Dongguan, Guangdong, China
Tel: (769) 81273588, Fax: (769) 81082986
E-mail: info@konglighting.com
sales@konglighting.com

PRODUCT SPECIFICATION

Model: KL1809-6P (S3636 RGB IC LED)

Description: Top SMD RGB (IC) LED

3 chips in 1 LED 0.3W(R G B)

(Built-in breakthrough IC)

Versions: 00

DATE: 2019-03-09

Formal specification

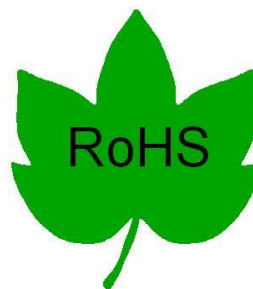



Kong Lighting Technology Ltd

HK Office: Flat 24, 8/F, Block A, Hoi Luen Industry Centre, 55 Hoi Yuen Rd, Kwun Tong, Kowloon, Hong Kong
Tel: (852) 2185 7600, Fax: (852) 2185 7608
WWW.Konglighting.com

China Factory: Lijiafang Industry Zone, Shipai, Zhen Dongguan, Guangdong, China
Tel: (769) 81273588, Fax: (769) 81082986
E-mail: info@konglighting.com
sales@konglighting.com

1. Features / Function Descriptions

KL1809-6P is a three-channel LED driver IC, driven by 12V power supply, high-precision constant current output, integrated with MCU digital interface, data latch, LED driver and other circuits. The peripheral gray MCU control realizes the individual gray scale and cascade control of the chip to realize the color dot matrix illumination control of the outdoor large screen.

Excellent product performance and reliable quality.

- Ø High voltage CMOS process, 12V single point single control
- Ø Output constant current value absolute accuracy $\pm 2\%$, RGB relative accuracy $\pm 1\%$
- Ø High efficiency, low power consumption, long transmission distance without discoloration
- Ø Default output constant current value 9mA, suitable for built-in lamp beads
- Ø default power-on does not light
- Ø Grayscale adjustment circuit (256 levels of grayscale adjustable)
- Ø Single-line serial cascading interface (DIN.DOUT)
- Ø Built-in high precision and high stability oscillator
- Ø Data shaping: automatically receive subsequent data shaping output after receiving the unit data
- Ø Data transmission rate 800Kbps

2. Product Application

- Ø Led point light source, Led pixel screen,
- Ø Led Symphony Soft Light Strip, Led Symphony Light Bar.
- Ø Led magical marquee, Led Symphony guardrail tube.
- Ø Led Symphony Lights, Led Symphony Lights.



Kong Lighting Technology Ltd

HK Office: Flat 24, 8/F, Block A, Hoi Luen Industry Centre, 55 Hoi Yuen Rd, Kwun Tong, Kowloon, Hong Kong
 Tel: (852) 2185 7600, Fax: (852) 2185 7608
WWW.Konglighting.com

China Factory: Liji Fang Industry Zone, Shipai, Zhen, Dongguan, Guangdong, China
 Tel: (769) 81273588, Fax: (769) 81082986
 E-mail: info@konglighting.com
sales@konglighting.com

3. LED Dimension (unit: mm)

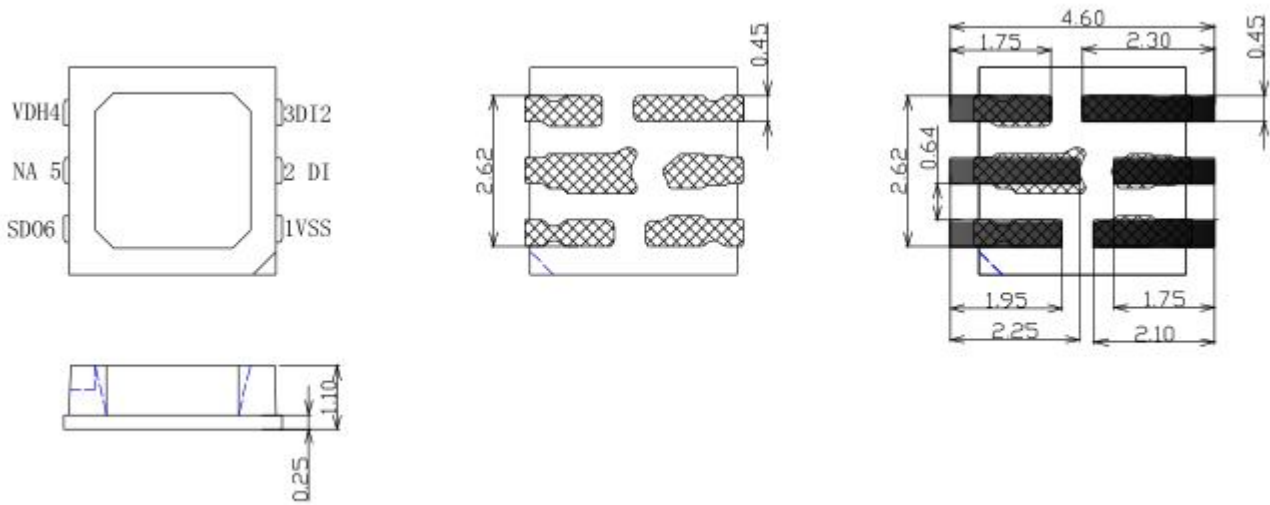

4. Pin function

Pin number	Symbol	Pin name	function description
1	GND	Chip ground	Negative power supply
2	SDI1	Date Input	Control signal date input
3	SDI2	Date Input	Control data signal redundancy input
4	VDD	Chip power	Positive power supply
5	NA	/	
6	SDO	Date output	Control signal date output



Kong Lighting Technology Ltd

HK Office: Flat 24, 8/F, Block A, Hoi Luen Industry Centre, 55 Hoi Yuen Rd, Kwun Tong, Kowloon, Hong Kong
 Tel: (852) 2185 7600, Fax: (852) 2185 7608
WWW.Konglighting.com

China Factory: Liji Fang Industry Zone, Shipai, Zhen, Dongguan, Guangdong, China
 Tel: (769) 81273588, Fax: (769) 81082986
 E-mail: info@konglighting.com
sales@konglighting.com

5. Limit parameters (TA = 25 ° C, VSS = 0 V unless otherwise specified)

Parameter	Symbol	Range	Unit
Power supply voltage	VDD	-0.4~14	V
Logic input voltage	VI	-0.5~VDD+0.5	V
R/G/B output current	IOUT	9	mA
Working temperature	Topt	-40~+85	°C
Storage temperature	Tstg	-50~+150	°C
ESD withstand voltage (HBM)	VESD	2K	V

6. Electrical characteristics (TA=25 °C)

Parameter	symbol	minimum	typical	maximum	unit
Chip supply voltage	Vin	10.8	12	13.2	V
R/G/B output drive current	IOUT	8.82	9	9.18	mA
High level input voltage	VIH	4	-	-	V
Low level input voltage	VIL	-	-	1	V
PWM frequency	fPWM	-	1.2	-	KHZ
Static power consumption	Idd	-	2	-	mA



Kong Lighting Technology Ltd

HK Office: Flat 24, 8/F, Block A, Hoi Luen Industry Centre, 55 Hoi Yuen Rd, Kwun Tong, Kowloon, Hong Kong
 Tel: (852) 2185 7600, Fax: (852) 2185 7608
WWW.Konglighting.com

China Factory: Liji Fang Industry Zone, Shipai, Zhen, Dongguan, Guangdong, China
 Tel: (769) 81273588, Fax: (769) 81082986
 E-mail: info@konglighting.com
sales@konglighting.com

7. Switching characteristics (T A =25 ° C)

Parameter	Symbol	Minimum	Typical	Maximum	Unit	Test Condition
Data transfer rate	FDIN	-	800	-	kHz	-
Transmission delay time	tPLZ	-	-	500	ns	-

8. Function description

The chip adopts single-line communication mode and uses a return-to-zero code to transmit signals. After the power-on reset, the chip receives the data from the DIN terminal. After receiving 24 bits, the DOUT port starts to forward data and provides input data for the next chip. The DOUT port is pulled low until it is forwarded. At this time, the chip will not receive new data. The three PWM output ports of the chips OUTR, OUTG, and OUTB send corresponding signals with different duty ratios according to the received 24-bit data. The signal period is 4ms. If the input signal of the DIN terminal is the Reset signal, the chip will send the received data to the display, and the chip will re-receive the new data after the end of the signal. After receiving the initial 24bit data, the data is forwarded through the DOUT port, and the chip is not received. Before the RESET code, the original output of the OUTR, OUTG, and OUTB pins remains unchanged. After receiving the low level RESET code of 80µs or more, the chip outputs the 24-bit PWM data pulse width just received to the OUTR. On the OUTG, OUTB pins.

The chip adopts automatic shaping and forwarding technology, so that the number of cascaded chips is not limited by signal transmission, and only the speed of the screen is limited. For example, we design a 1024 cascade, which has a screen time of $1024 \times 0.4 \times 2 = 0.8192\text{ms}$ (the chip's data delay time is $0.4\mu\text{s}$) without any flickering.



Kong Lighting Technology Ltd

HK Office: Flat 24, 8/F, Block A, Hoi Luen Industry Centre, 55 Hoi Yuen Rd, Kwun Tong, Kowloon, Hong Kong
 China Factory: Liji Fang Industry Zone, Shipai, Zhen, Dongguan, Guangdong, China
 Tel: (852) 2185 7600, Fax: (852) 2185 7608
 WWW.Konglighting.com
 Tel: (769) 81273588, Fax: (769) 81082986
 E-mail: info@konglighting.com
sales@konglighting.com

9. LED photoelectric parameters

Color	Main wavelength (nm)	The luminous flux(LM)	Default Max current	Operating voltage (V)
Red	620-625nm	0.8-1.6	9	1.8-2.2
Green	520-525nm	2.0-4.0	9	2.6-3.0
Blue	465-470nm	0.5-1.0	9	2.8-3.2

10. Timing waveform diagram

1) . Input pattern

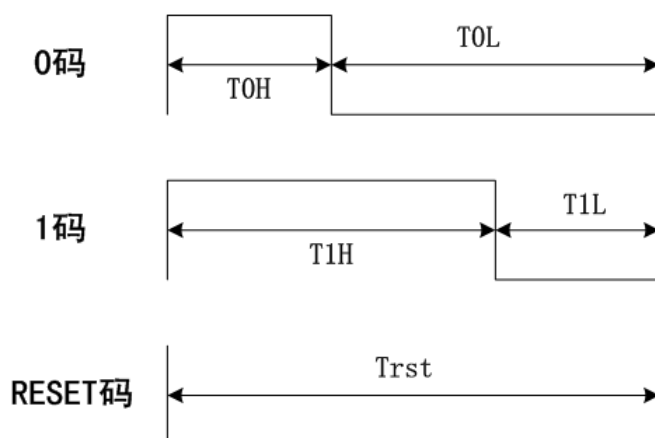

2). Pattern time

Item	Description	typical value	Allowable error
T_{OH}	0 code, high voltage time	0.3us	$\pm 0.05us$
T_{1H}	1 code, high voltage time	0.9us	$\pm 0.05us$
T_{OL}	0 code, low voltage time	0.9us	$\pm 0.05us$
T_{1L}	1 code, low voltage time	0.3us	$\pm 0.05us$
T_{rst}	Reset, low voltage time	$\geq 80 us$	-



Kong Lighting Technology Ltd

HK Office: Flat 24, 8/F, Block A, Hoi Luen Industry Centre, 55 Hoi Yuen Rd, Kwun Tong, Kowloon, Hong Kong
 Tel: (852) 2185 7600, Fax: (852) 2185 7608
WWW.Konglighting.com

China Factory: Liji Fang Industry Zone, Shipai, Zhen, Dongguan, Guangdong, China
 Tel: (769) 81273588, Fax: (769) 81082986
 E-mail: info@konglighting.com
sales@konglighting.com

11. Typical application circuit

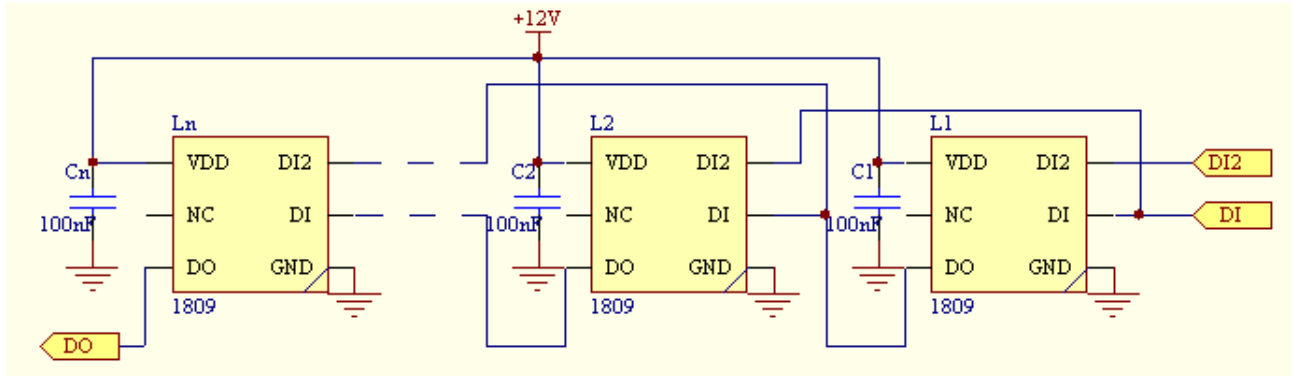

Characteristic of temperature curve	Lead-Based Solder	Lead-Free Solder
Average Ramp-Up Rate (Ts 1max to Tp)	3°C/ second max	3°C/ second max
Preheat: Temperature Min (Ts1 min) ~ Max (Ts2 max)	100°C ~ 150°C	150°C ~ 200°C
Preheat: Time (Ts1 to Ts2)	60-150 seconds	60-150 seconds
Time Maintained Above: Temperature (TL)	183°C min	217°C min
Time Maintained Above: Time (tL)	30-80 seconds	30-80 seconds
Peak/Classification Temperature (Tp)	220°C	240°C
Peak Temperature (tp) limit	5-10 seconds	5-10 seconds
Ramp-Down Rate	6°C /seconds max	6°C /seconds max
Reflow time	6 minutes max	6 minutes max

Note of reflow

1. Before use, please put product in 65-70°C of baking in the oven for 24 hours
2. Please used the product within 2 hours when it remove from the oven
3. Please put back into the oven if the product did not use
4. When the shift or resting make sure the paste is completed the product which no paste put it back into the oven